

Medium / Large Capacity Fine Fog Nozzles

GBIM series Nozzles



■ GBIM series fine fog nozzles are large capacity pneumatic spray nozzles generating fine fog with very low air-water ratios.

■ GBIM series nozzles save running costs with low consumption of compressed air due to their very low air-water ratios.

Contents

GBIM series
Medium / Large Capacity
Fine Fog Nozzles

p.37

Medium / Large Capacity Fine Fog Nozzles

GBIM

Features

- Produces fine atomization having a mean droplet diameter of 60 μ m and a maximum droplet diameter of 150 μ m (*1), with spray capacity 700 ℓ /hr at an air-water ratio of 100. Low air-water ratio design.
- Spray angle is 60°.
- Compact. Nozzle tip designed for heavy-duty environments such as a cooling tower after an incinerator.

*1) Measured by Laser Doppler Method

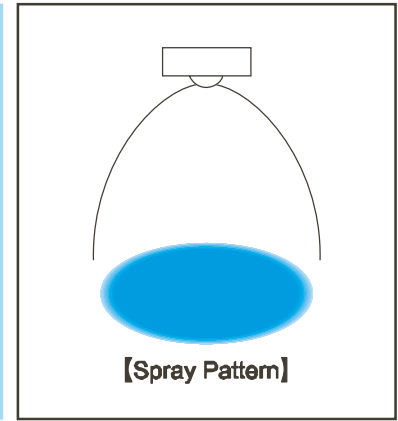

Applications

- Cooling: Gas, molding, refractories
- Moisture control: Paper, gas, concrete
- Combustion: Oil

Structure & Materials

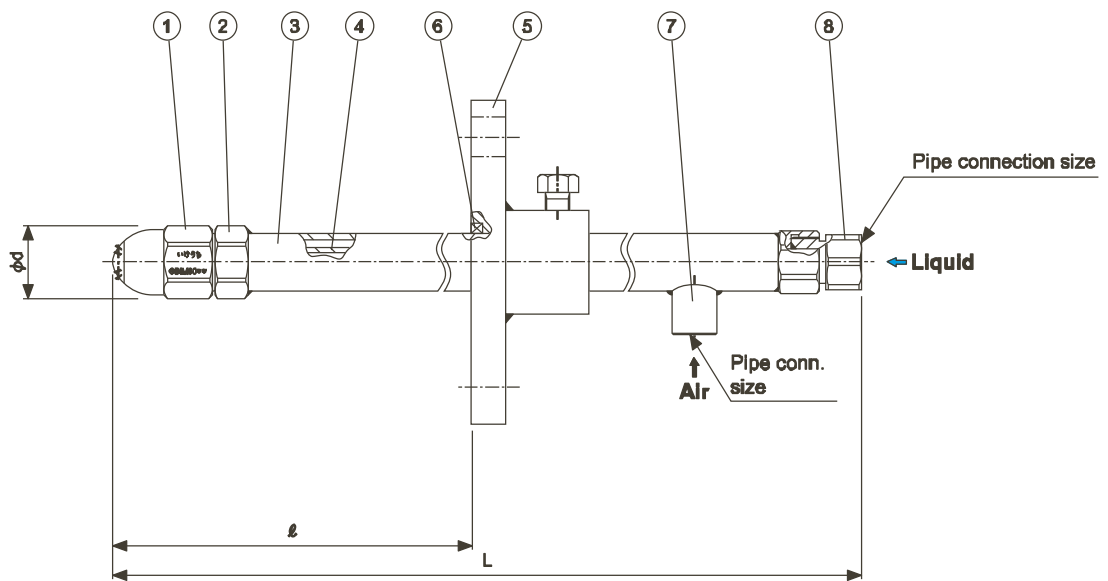

Components and materials

No.	Component	Standard Material
①	Nozzle Tip & Cap	S316L
②	Adaptor	S316L
③	Outer Pipe (for air)	S316LTP
④	Inner Pipe (for liquid)	S304TP
⑤	Flange	S304
⑥	Packing	Ceramic fiber + Stainless steel wire
⑦	Air Connection	S304
⑧	Liquid Connection	S304

Dimensions

Spray Angle Code	Air Consumption Code	Pipe Conn. Size		Outer Diameter ϕd (mm)	Free Passage Diameter (mm)	
		Air	Liquid		Air	Liquid
60°	75	1/2F		45	2.4	2.5
	110	1/2F			2.4	2.7
	150	3/4F	1/2F	50	3.1	3.4

Nozzle length

Type	Total Length L (mm)	Length ℓ (mm)
A	560	300~400
B	760	400~600
C	960	600~800
D	1160	800~1000

Flow-rate Diagram

How to read the chart

- ① The spray capacity shown is for one nozzle.
- ② Red lines (—) represent compressed air pressures P_a in MPa.
Blue lines (—) represent liquid pressures P_w in MPa.
Green lines (—) represent air-water ratio Q_a/Q_w .
- ③ Figures in ovals \bigcirc indicate Sauter mean droplet diameters (μm) measured by the Laser Doppler Method.

GBIM6075

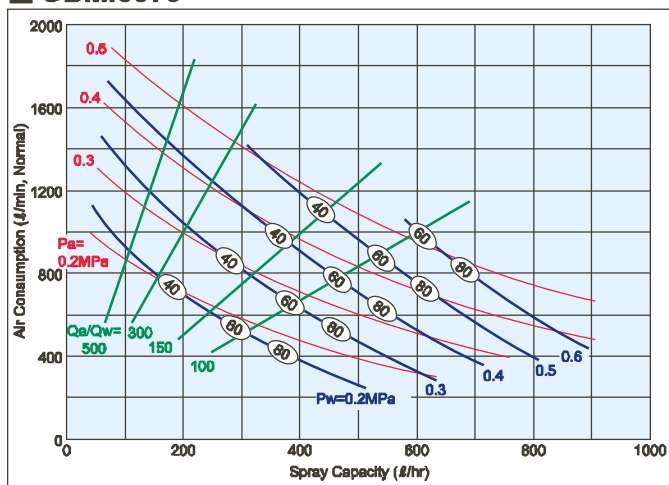

GBIM60110

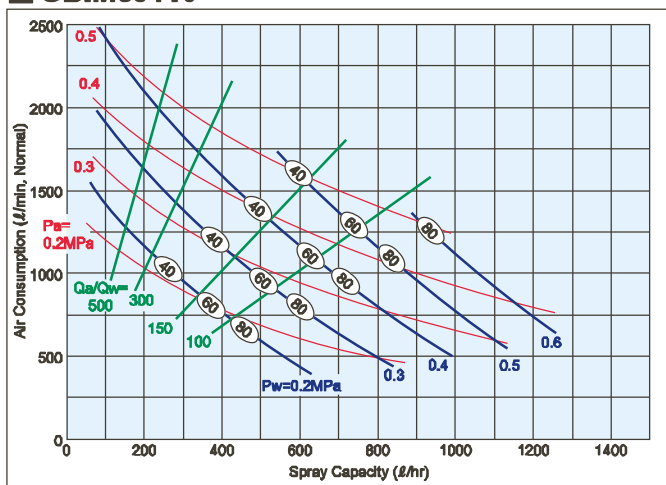

GBIM60150

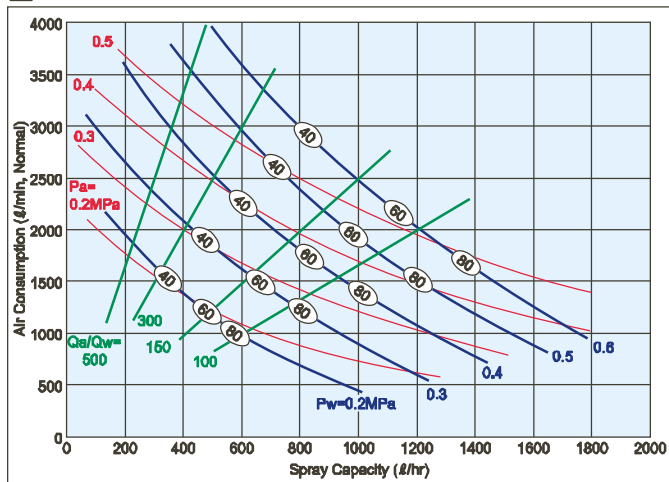

Spray Dimensions

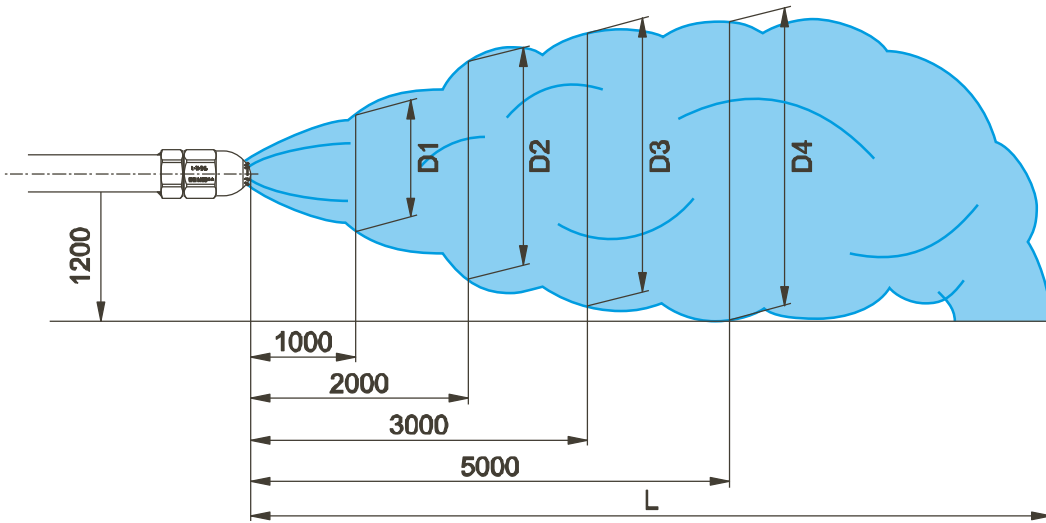

Spray Angle Code	Air Consumption Code	Air Pressure (MPa)	Liquid Pressure (MPa)	Spray Dimensions (mm)				
				D1	D2	D3	D4	L
60°	75	0.3	0.25~0.35	800	1200	1500	2000	8000
		0.4	0.35~0.45	700	1100	1400	2000	8000
		0.5	0.45~0.55	650	1050	1300	2000	9000
	110	0.3	0.25~0.35	850	1250	1550	2100	9000
		0.4	0.35~0.45	750	1150	1450	2100	9000
		0.5	0.45~0.55	700	1100	1400	2100	10000
	150	0.3	0.25~0.35	900	1300	1600	2200	10000
		0.4	0.35~0.45	800	1200	1500	2200	10000
		0.5	0.45~0.55	750	1150	1450	2200	11000

How to order

Please inquire or order for a specific nozzle using this coding system.

<Example> GBIM 60110 C S316L+2T10S304(SCS13)(l)

GBIM	60	110	C	S316L +	2T10	S304(SCS13)	(l)
		Air Consumption Code	Nozzle Length		Flange Size		Length between the nozzle head and flange
		■75	■A				
		■110	■B				
		■150	■C				
			■D				
			(See p.37)				